



1600 Fork Truck has high visibility for sensitive loads.



Swinger articulated wheel loaders lift 1,200 to 3,000 lbs.

**handle  
with care**

*photos may show optional equipment*

# **SWINGER**

## **1600 Rough Terrain Forklift Truck**

### **SUPER BEE**

Swinger features include dedicated straight mast frame, high visibility overhead guard, increased knee room, reinforced articulation system, 32 hp 4 cylinder Kubota engine, improved rocker pedal direction control, sealed-connection wiring, easy-access service points, key switch for glow plugs and ignition, vibration reduction — and more.

Swinger has a smooth and gentle touch. It features independent front and rear frames which “oscillate” over rough terrain. Ideal for carrying loads from delicate bee hives to palletted bags and construction block. The high visibility straight-mast allows easy fork positioning — has ±10° tilt — 1,600 lbs. lift capacity.

Plus, Swinger is simple to operate. Has articulated steering. No levers or tire skidding in turns (easy on turf).

# Swinger 1600 Rough Terrain Forklift Truck

## Specifications subject to change without notice

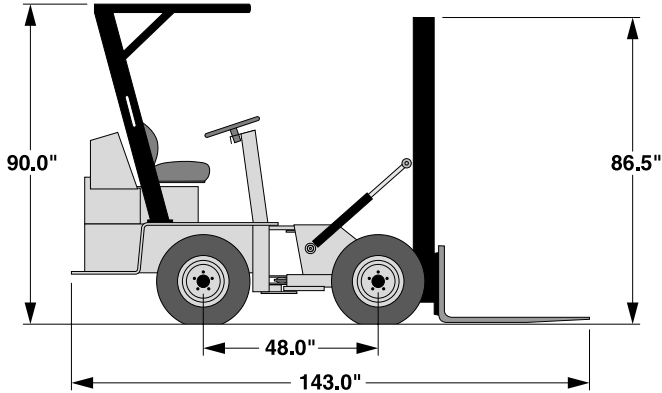
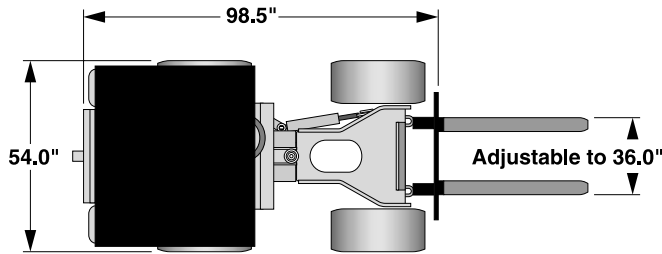

## Weights and Capacities

Operating weight.....	4,500 lbs.
Operating capacity @ 24" (600 mm).....	1,600 lbs.
Fuel.....	6.5 gal.
Cooling System.....	18 qts.

## Dimensions & Data

Length with 42" forks.....	143"	Wheel base.....	48"
Length without forks.....	98.5"	Over Tires, width.....	54"
Height to top of o/h guard.....	90"	Travel speed.....	9 mph
Ground clearance.....	8.25"	Articulation.....	±40°
Turning radius.....	39"	Oscillation.....	±6°
		Maximum lift height.....	126" (3.2m)

## Standard Equipment

Kubota 1505E 4-cyl diesel	Oil Pressure Gauge
35 amp. alternator	Voltmeter
Disc type parking brake	Fuel Gauge
Overhead Guard	Back-up Alarm
Adjustable Seat	Mast
Seat Belt	3-spool, 3-lever hydraulic valve
Horn	42" Forks
Engine Hourmeter	26.5 x 12-12 Hi-float Tires
Coolant Temperature Gauge	Rear Receiver Hitch

## Optional Equipment

- 27 x 8.5-15 6-ply Bar Lug Tires, (calcium filled)
- 26 x 12-12 Turf and Sand Tires, 4-ply
- Light Package: 2 Headlights, 1 Taillight, 1 Rear Worklight
- Catalytic Converter
- Touch-up Paint, Suspension Seat, Mast Side Shift

## Engine

Kubota® 1505E — diesel, 4-cylinders, 32 (net) maximum H.P., 1.5 L (91.5 cu. in.) displacement. Engine oil capacity (including filter) is 6.4 qts.

## Drive System

Hydro/mechanical — Hydrostatic power coupled through reduction gearbox to mechanical final drive.

## Hydraulic System

Hydrostatic pump..... Eaton®, 2.48 cu. in., 4,500 psi  
 Auxiliary pump..... Eaton, 14.5 gpm, 2,500 psi  
 Hydraulic motor..... Eaton, 2.01 cu. in., 4,500 psi  
 Filter..... 15 micron, absolute  
 Reservoir..... 5.2 gal.  
 Cylinders:

Cylinder Type	# of Cylinders	Stroke	Bore
Steering	1	10.4"	2.5"
Lift Mast	2	63.0"	2.0"
Tilt Mast	2	8.0"	2.5"
Side Shift	1	6.0"	2.0"

## Mechanical Drive Train

Gearbox Reduction ratio..... 5:1      Gearbox Lube Capacity..... 1 qt.  
 Axle Reduction ratio..... 5.38:1      Differential Lube  
 Total Reduction ratio..... 26.9:1      Capacity..... 4.5 qts.

## Control Valve

Lift and Lower..... 1 Lever      Side-Shift (Optional)..... 1 Lever  
 Tilt..... 1 Lever      Forward/reverse..... single pedal

## Braking

Parking brake..... mechanical disc on driveshaft

## Electrical System

Alternator..... 35 amps      Battery..... 530 cold crank amps  
 Ground..... negative      Starter..... 12-volt

## The simple Swinger hydrostatic-over-mechanical drive system

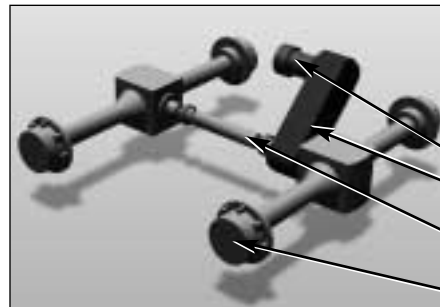

Swinger features simple, durable, easy maintenance drive system. Hydrostatic motor drives gear reducer. It's mechanical drive from the reducer to the wheels.



## National Swinger Distributor

### Apiaries & Orchard Forklift, Inc.

7340 Vickeryville Rd., Edmore, MI 48829  
**Sales, service, parts and advice, call 800-943-8677 • Fax: 989-427-5002**  
 E-mail: [swinger@swingerforklift.com](mailto:swinger@swingerforklift.com)  
 Website: [www.swingerforklift.com](http://www.swingerforklift.com)

## SWINGER

Loader Division of NMC-WOLLARD, Inc.  
 2021 Truax Blvd.,  
 Eau Claire, WI 54703  
 Phone 715-835-3151  
 Fax 715-833-8708  
 E-mail: [loaders@nmc-wollard.com](mailto:loaders@nmc-wollard.com)  
[www.nmc-wollard.com](http://www.nmc-wollard.com)